

7' POST BOX #1

0300-06-010 PART OF 0300-00-003

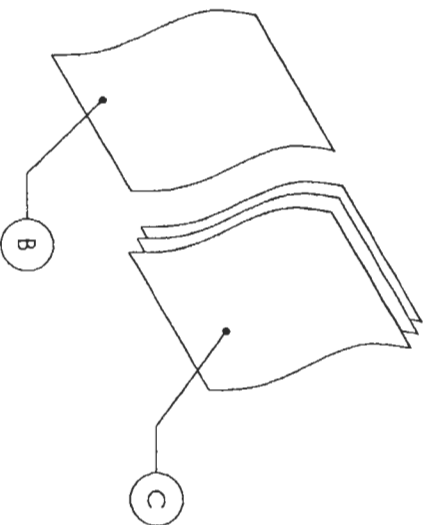

#	QTY.	PART NAME	PART DESCRIPTION
A	1	PT7-BOX #1	SHIPPING BOX #1
B	1	PT7-PARTS #1	PARTS LIST FOR BOX #1
C	1	PT7-INSTALL	INSTALLATION INSTRUCTIONS
D	1	PT-CHP	COVER PLATE
E	1	CH5-R	CONNECTOR LOCKER RIGHT
F	1	CH5-L	CONNECTOR HANGER LEFT
G	2	RETRACTOR KIT	RETRACTOR/CRS KIT
H	2	DOOR LOCKS	LATCH LOCK + KEY
I	2	CABLE CLAMPS	CABLE CLAMP BAGS
J	4	SCREW "A"	FOR CHARGER
K	4	SCREW 'B'	FOR CONNECTOR HANGERS
L	4	SCREW 'E'	FOR RETRACTORS

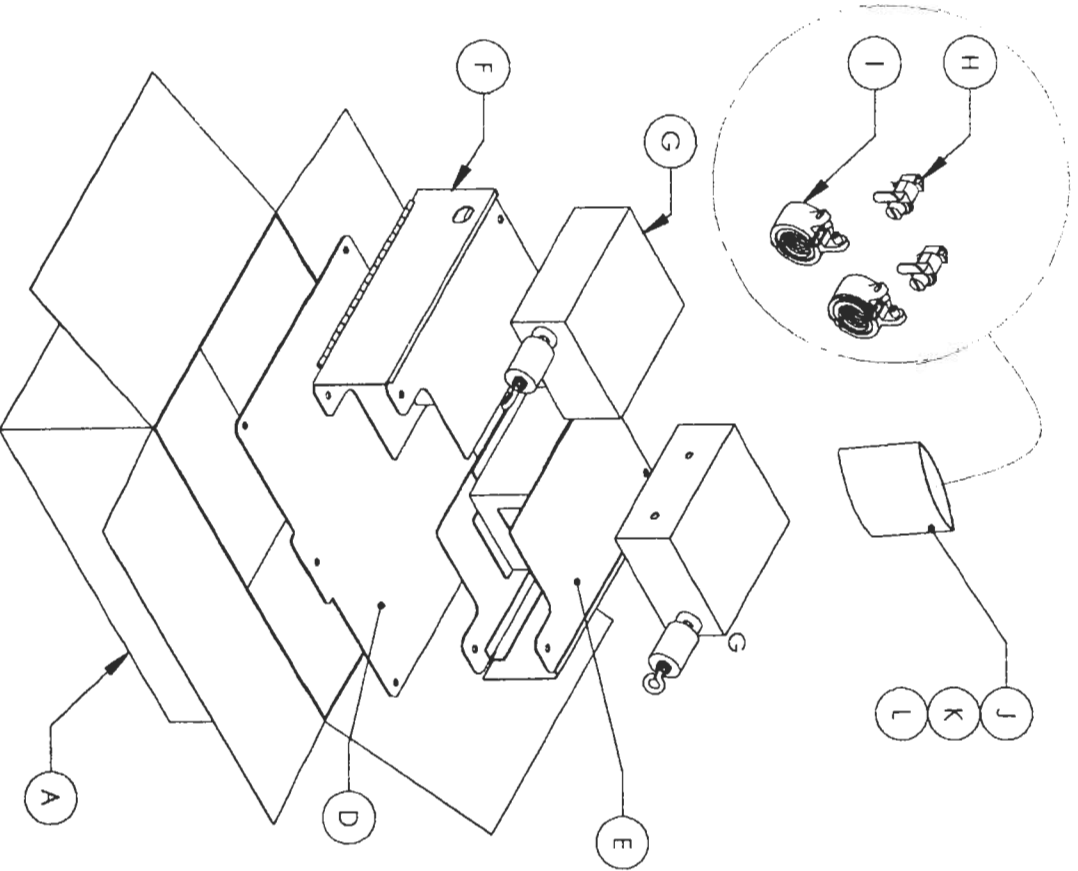

DRAWN: T.A.W. 27 NOV 01
 SITE: PT7-PARTS #1
 SCALE: 1/12
 WEIGHT:
 SHEET 1 OF 2

ELECTRIC VEHICLE INFRASTRUCTURE
 REV: A1

7' POST BOX #2

0300-06-011 PART OF 0300-00-003

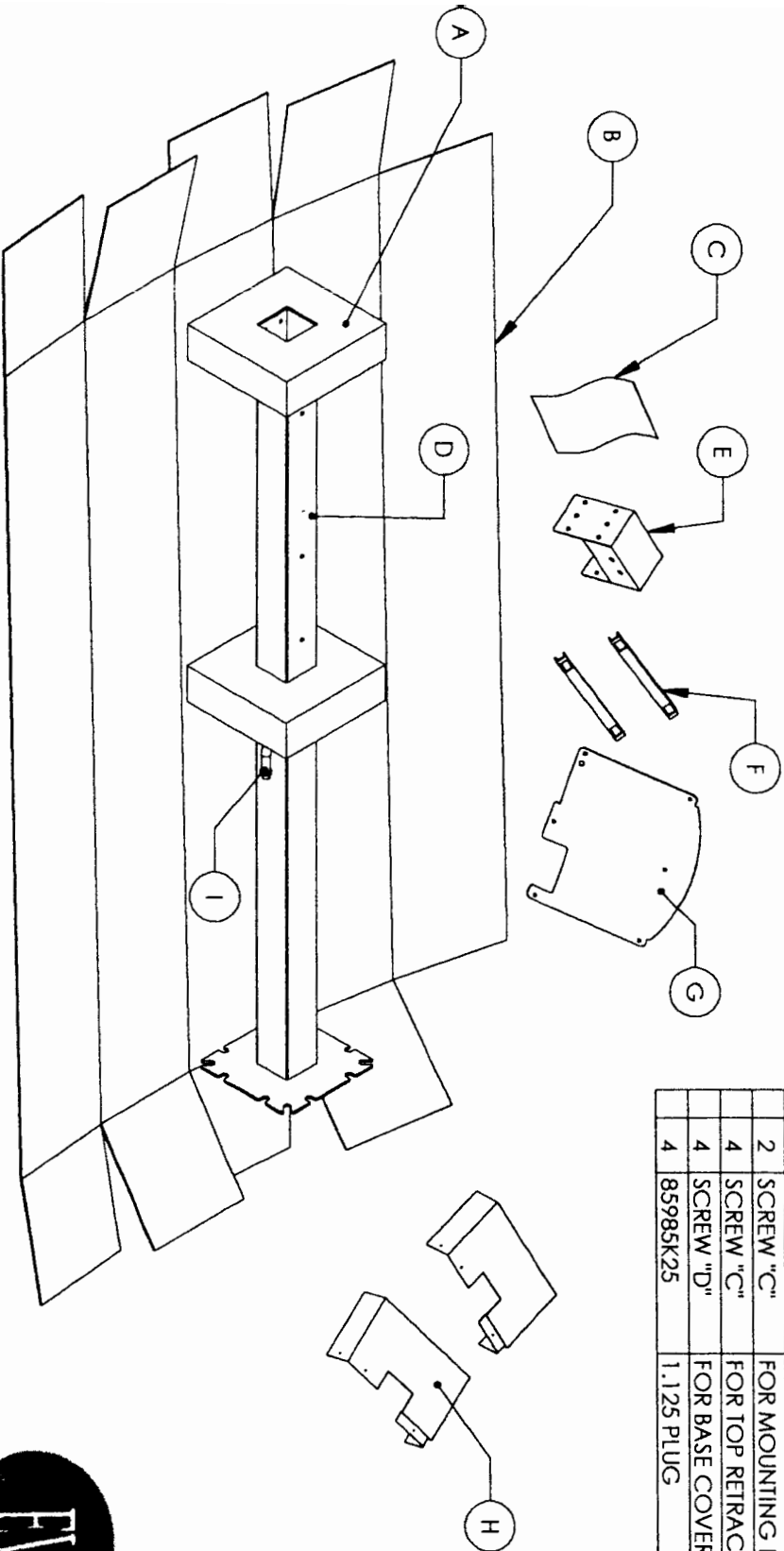

#	QTY.	PART NAME	PART DESCRIPTION
A	2	PT7-SPCRS	CARDBOARD SPACERS
B	1	PT7-BOX #2	SHIPPING BOX #2
C	1	PT7-PARTS #2	PARTS LIST FOR BOX #2
D	1	PT-7	7' POST
E	1	PT-TRM	TOP RETRACTOR MOUNT
F	2	PT-BST	BASE STIFFENERS
G	1	2B-07	2B- MOUNTING PLATE
H	2	PT-03	BASE COVER
I	1	2B-COND	CONDUIT CONNECTION
	4	SCREW "A"	FOR SIGN
	2	SCREW "A"	FOR COVER PLATE
	2	SCREW "C"	FOR MOUNTING PLATE
	4	SCREW "C"	FOR TOP RETRACTOR MOUNT
	4	SCREW "D"	FOR BASE COVER
	4	85985K25	1.125 PLUG



DRAWN 1.A.W. 27 NOV/01
DO NOT SCALE DRAWING

ELECTRIC VEHICLE INFRASTRUCTURE
SITE DWG. NAME: PT7-PARTS #2
SCALE: 1/2" = 1'-0"
WEIGHT: A1
REV. A1
SHEET 2 OF 2

7 FOOT POST:
CONNECTOR ENCLOSURE INSTALLATION

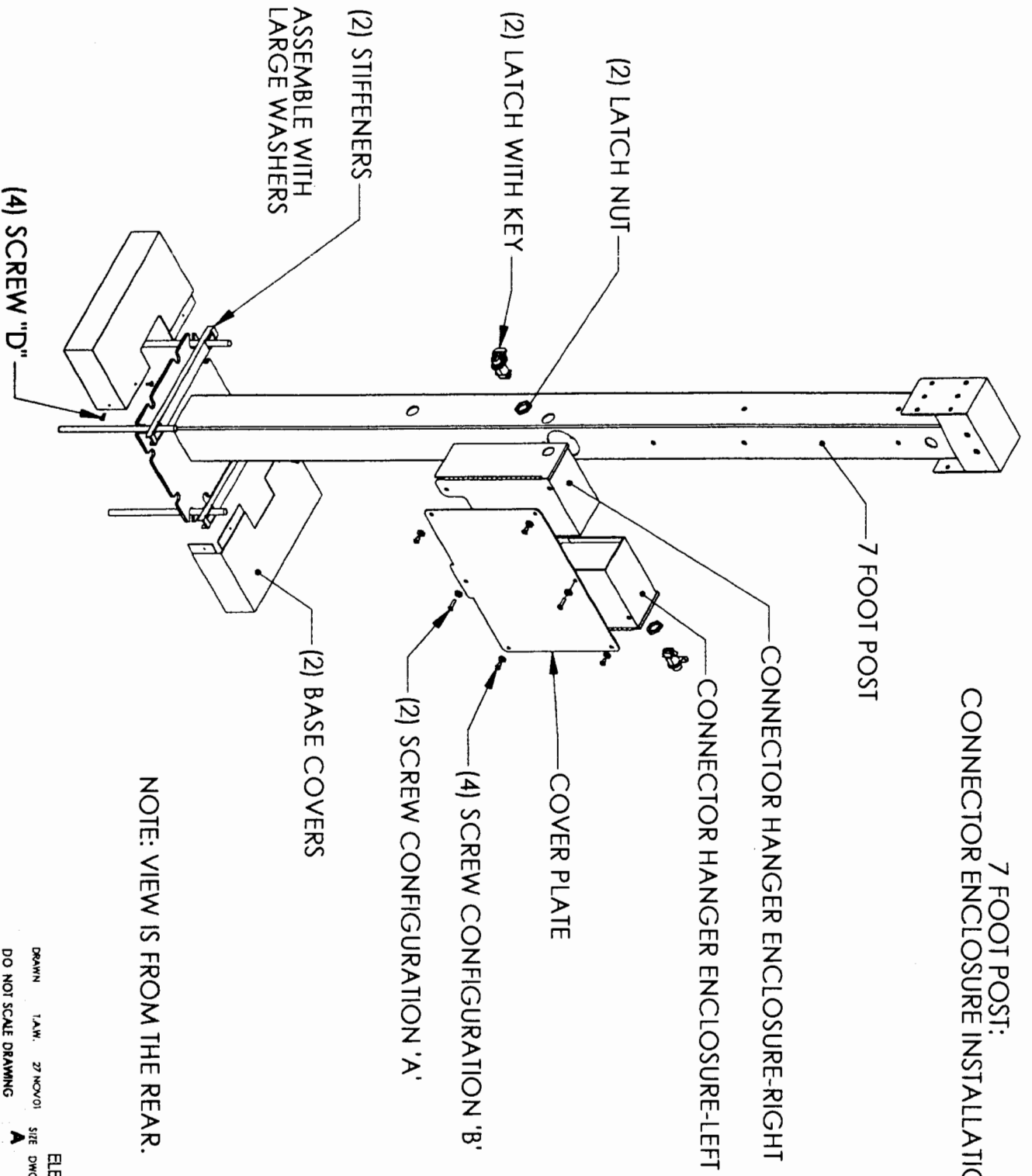

NOTE: VIEW IS FROM THE REAR.



ELECTRIC VEHICLE INFRASTRUCTURE
 DRAWN: T.A.W. 27 NOV 01
 SIZE: A
 DWG. NAME: PT7-CONN-ENCL-INSTALL
 DO NOT SCALE DRAWING
 SCALE: 1/2" = 1'-0"
 WEIGHT:
 REV. SHEET 1 OF 1

7' POST
CHARGER AND CLAMP INSTALLATION

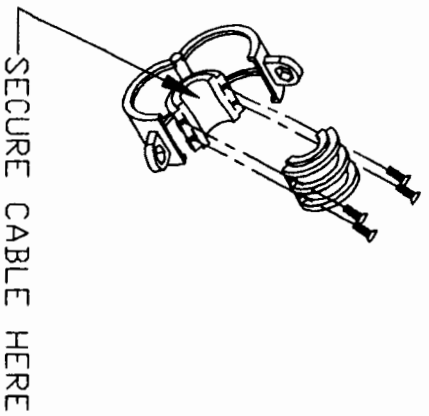
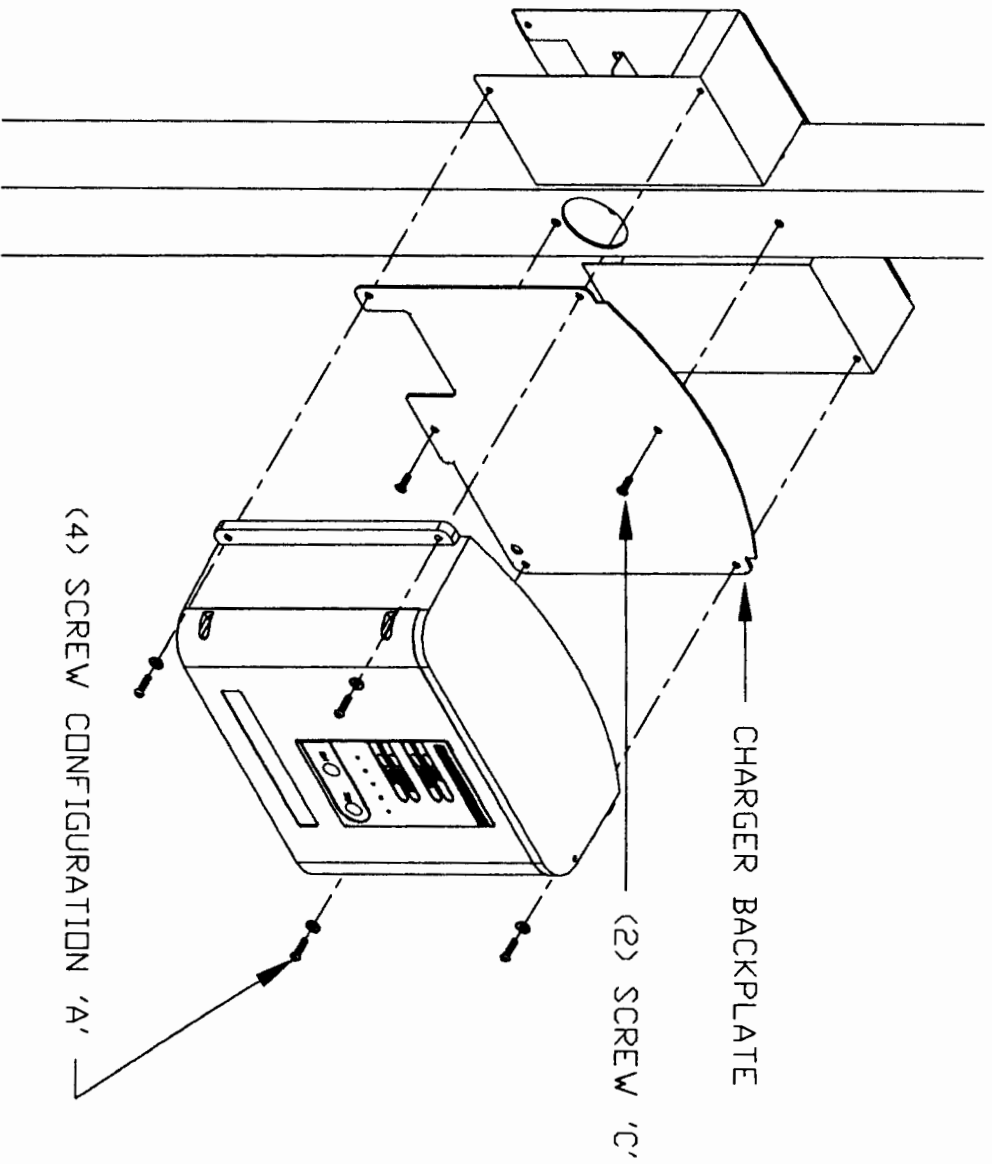

CABLE MOUNTING NOTE:
MOUNT CABLE CLAMP 11 FEET
FROM END OF CONNECTOR.

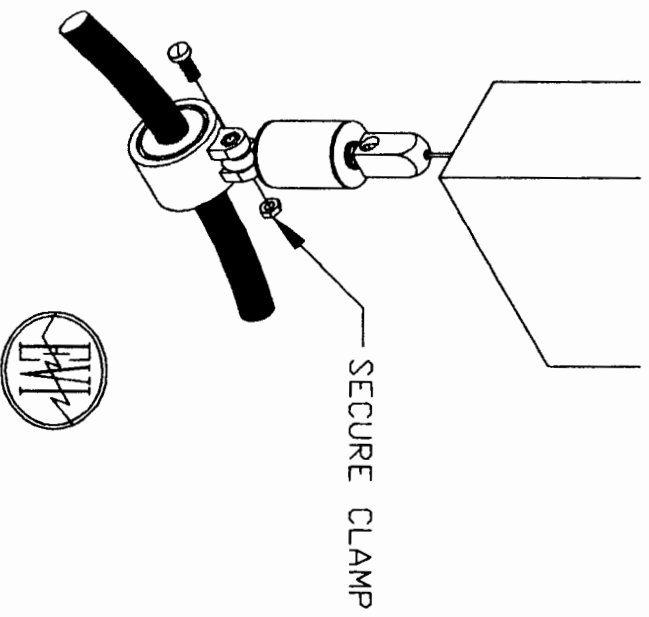

ELECTRIC VEHICLE INFRASTRUCTURE
11839 INDUSTRIAL COURT, AUBURN CALIFORNIA 95603
OFFICE: (530) 823-8077 FAX: (530) 823-0857

RETRACTOR TO 7 FOOT POST SUB-ASSEMBLY

#	DESCRIPTION
A	1 7 FOOT POST
B	4 SCREW 'C'
C	2* SCREW CONFIGURATION 'E'
D	1 RETRACTOR MOUNT
E	1-4 RETRACTOR SUB-ASSEMBLY

* PER RETRACTOR

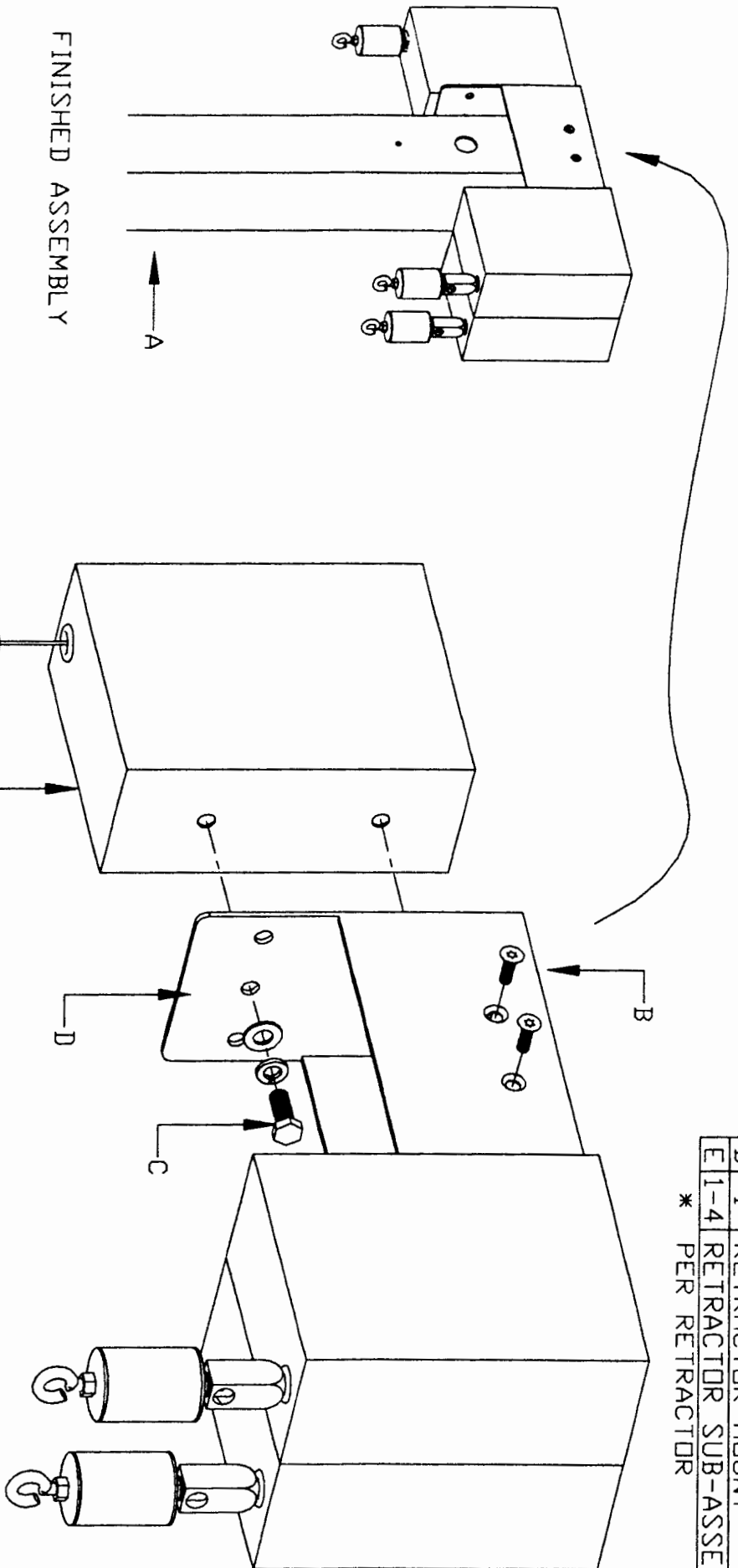

FINISHED ASSEMBLY

NOTE:
ONE TO FOUR RETRACTORS CAN BE INSTALLED.



ELECTRIC VEHICLE INFRASTRUCTURE
11839 INDUSTRIAL COURT, AUBURN CALIFORNIA 95603
OFFICE: (530) 823-8077 FAX: (530) 823-0857

POST HARDWARE LIST

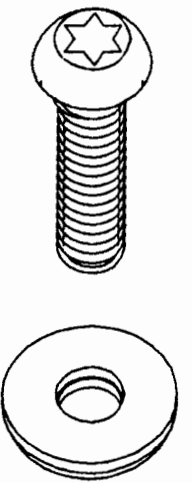

SCREW CONFIGURATION 'A'
1/4-20 X 1" LONG BUTTON HEAD TORX SCREWS
1/4" SEAL BONDING WASHERS
TDDL: T-27 TORX BIT
TORQUE: 34 IN/LBS.

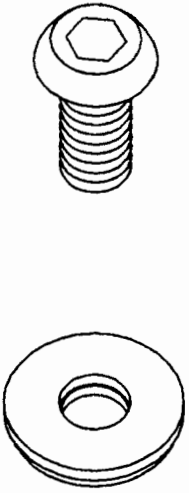

SCREW CONFIGURATION 'B'
1/4-20 X 5/8" LONG BUTTON HEAD ALLEN SCREWS
1/4" SEAL BONDING WASHERS
TDDL: 5/32 ALLEN WRENCH
TORQUE: 34 IN/LBS.

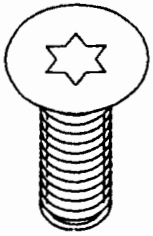

SCREW 'C'
1/4-20 X 3/4" LONG FLAT HEAD TORX SCREW
TDDL: T-27 TORX BIT
TORQUE: 34 IN/LBS.



SCREW 'D'
#6-32 X 1/2" LONG FLAT HEAD PHILLIPS SCREW
TDDL: #2 PHILLIPS HEAD SCREW DRIVER

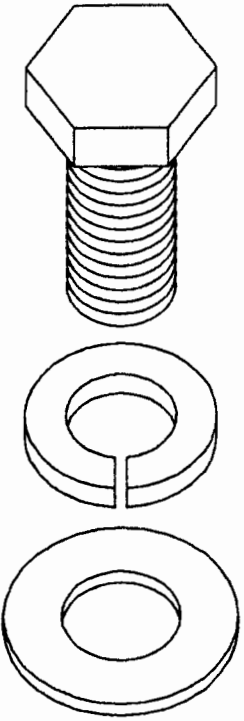

SCREW CONFIGURATION 'E'
3/8-16 X 1" LONG HEX HEAD SCREWS
3/8" SPLIT LOCK WASHERS
3/8" FLAT WASHERS
TDDL: 9/16 SOCKET ON RATCHET
TORQUE: 40 IN/LBS.



ELECTRIC VEHICLE INFRASTRUCTURE
11839 INDUSTRIAL COURT, AUBURN CALIFORNIA 95603
OFFICE: (530) 823-8077 FAX: (530) 823-0857