

DS-200 INSTALLATION GUIDE

Before You Begin

Read these instructions completely.

Note to Installer

Be sure to leave these instructions with the user.

Note to User

Keep these instructions for further reference.

SAFETY INSTRUCTIONS

The DS-200 Charge Station is designed with the safety concerns of the consumer as an utmost priority; however, the following safety precautions must be read and followed:

- The EVSE (Electric Vehicle Service Equipment) should be installed by a qualified electrician in accordance with local electrical codes and ordinances.
- Grounding Instructions - The charge station should be connected to a grounded, metal, permanent wiring system; or an equipment-grounding conductor should be run with circuit conductors and connected to the grounding terminal on the charger. Connections to the charge station should comply with all local codes and ordinances.
- Call your local service provider anytime a procedural question arises; DO NOT attempt to perform a procedure you are unsure of.
- Read all installation instructions carefully before performing the installation

WARNING *THIS MEANS DANGER. You are in a situation that could cause bodily injury. Before you work on any electrical equipment, be aware of the hazards involved with electrical circuitry and standard practices for preventing accidents.*

INSTALLATION REQUIREMENTS

Inventory

- Either Wall or Pedestal Mount DS-200 Charge Station
- DS-200 User's Guide
- DS-200 Installation Guide

Special Tools and Requirements

- A manufacturer-approved pedestal for pedestal-mount charge station.
- SAE wrench set or equivalent, Phillips head screwdriver, T-15 & T-27 Torx wrenches.
- Each charge station requires a dedicated 208 / 240 VAC, 50/60 HZ, single-phase, 60 amp circuit.
- Wire the EVSE to the breaker panel using wire sized according to local electrical codes.
- The electrical junction box for a wall mounted charge station should be installed approximately 42 inches above ground level.
- The pedestal mounted charge station should have the pedestal mounted in place according to the siting instructions.
- The charge station should be located to allow the charge cable to reach the vehicle's charge port.

Electric Vehicle Infrastructure, Inc.

11839 Industrial Court

Auburn, California 95603

Office: 530-823-8077 or 888-823-8077 Fax: 530-823-0857 Web: www.evii.com



SITE AND WIRING REQUIREMENTS

Concrete Pad Requirements

- Use (4) 5/8" or 1/2" anchor bolts in a 10" square pattern or (4) 3/8" anchor bolts in a 5.25" x 11.1" pattern (same as Delco).
- Anchor bolts should protrude not more than 2-7/8" above pad.
- Concrete pad should be at least 18" x 18" x 12" deep.

Wall Mounting Requirements

- Refer to the illustration for wall mounting dimensions.

Pedestal Wiring Harness, Single Unit

- One - 60 amp branch circuit, consisting of:
 - 2 - #8 Hot leads (1 RED*, 1 BLK*)
 - 1 - #8 Ground (GREEN)

Pedestal Wiring Harness, Double Unit

- Two - 60 amp branch circuits, consisting of:
 - 4 - #8 Hot leads (2 RED*, 2 BLK*)
 - 1 - #8 Ground (GREEN)

(* Each "Hot" lead must measure 120 volts to GND.)

General Wiring Requirements

- 1" or larger conduit required for single charge stations.
- 1-1/4" or larger conduit required for dual charge stations.
- Wire terminates in DS-200 enclosure.
- Refer to the illustration for location of knock-outs in the enclosure.
- Electrician will connect to the terminal block connections inside the DS-200 enclosure.
- Comply with local and NEC codes.

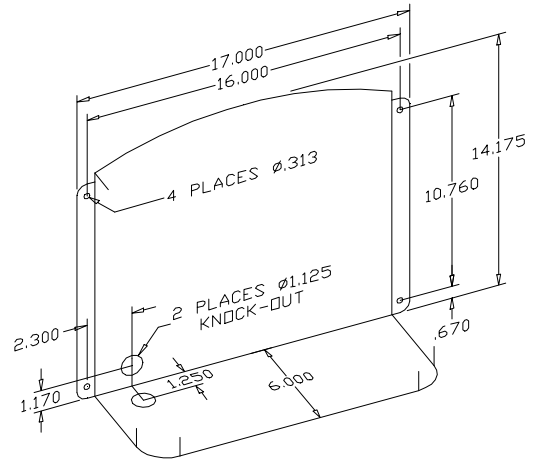
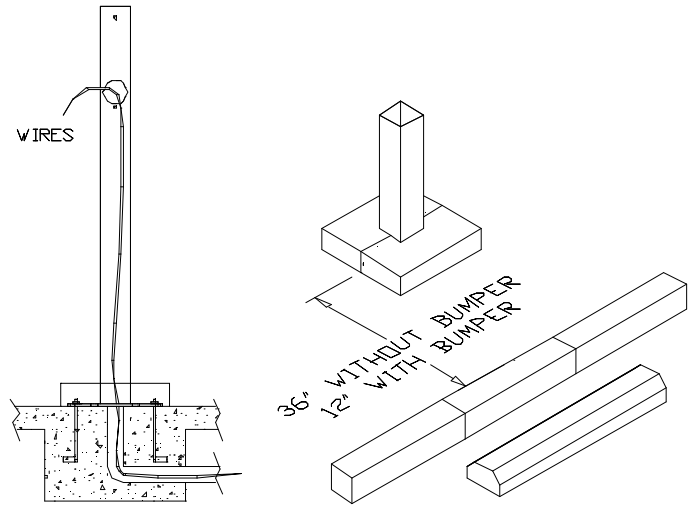

INSTALLING THE PEDESTAL BASE

1. Run the power conductors up through the pedestal and out the access hole.
2. Mount and secure the pedestal with four washers and nuts.

Note Power conductors must reach at least 48 inches above ground-level to reach the DS-200.

3. Install the pedestal base cover using (4) #8-32 flat head Phillips head screws.

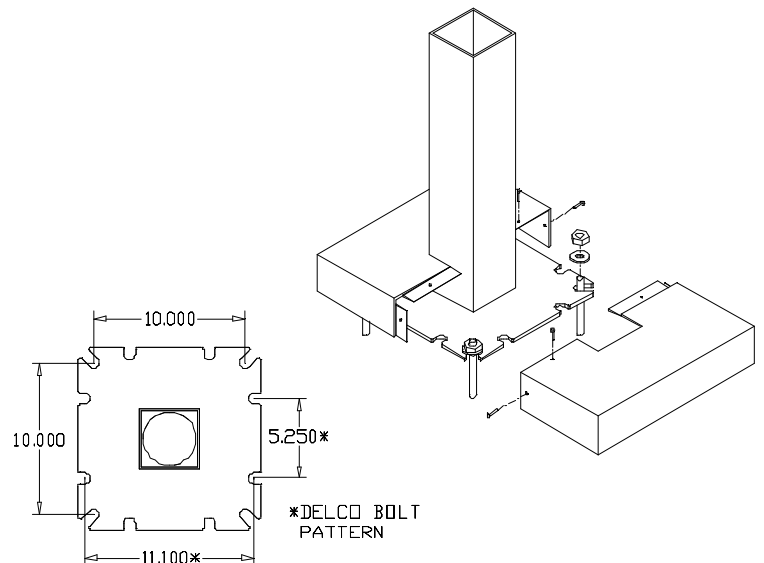

PEDESTAL MOUNTING

Single DS-200 Pedestal Mounting

1. Run the power leads out through the flexible conduit on the side of the pedestal.
2. Attach the mounting plate to the pedestal using (2) ¼-20 flat head screws with washers.
3. Attach the back cover plate to the pedestal using (2) ¼-20 button head screws with washers.
4. Install the pedestal cap using (2) ¼-20 button head screws with washers.
5. Mount the DS-200 to the mounting plate and back cover using (4) 1/4-20 button head screws with washers.
6. Remove (2) #8-32 button head screws with washers from the front door of the DS-200 enclosure and open the door.
7. Remove the applicable knock-out in the back of the charge station, push the power leads through the hole, then connect the flexible power conduit to the hole.

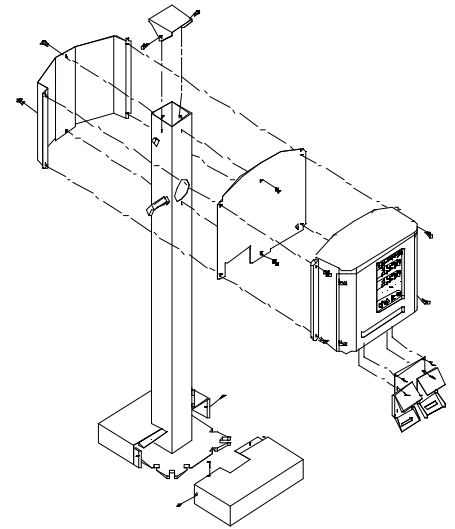

Double DS-200 Pedestal Mounting

1. Run the power leads out through the (2) flexible conduits on both sides of the pedestal.
2. Attach (2) mounting plates to the pedestal using (2) ¼-20 flat head screws for each mounting plate.
3. Install the pedestal cap using (2) ¼-20 button head screws with washers.
4. Temporarily mount both the side covers to one of the mounting plates. Use (1) ¼-20 button head screw to hold each side plate in place.
5. Mount the first DS-200 to the other mounting plate using (4) ¼-20 button head screws with washers.
6. Remove the (2) temporary screws used to hold the side covers in place then mount the second DS-200 using (4) ¼-20 button head screws with washers.
7. Remove (2) #8-32 button head screws with washers from the front doors of the (2) DS-200 enclosures and open their doors.
8. Remove the applicable knock-out in the back of each charge station, push the power leads through the holes, then connect the flexible power conduits to each hole.

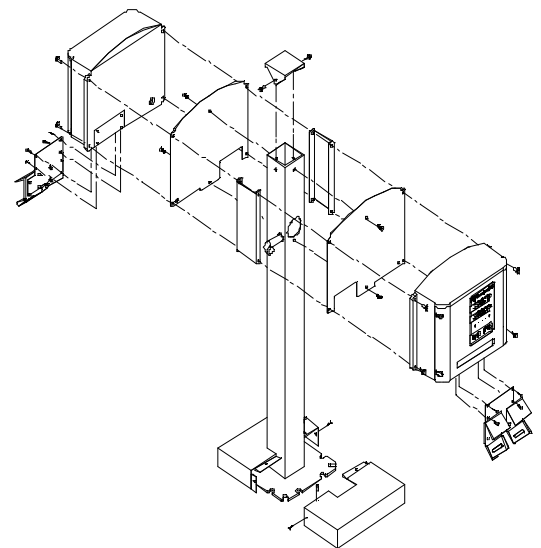

WALL MOUNTING

1. Locate the wall mounting position of the EVSE:
 - Position the bottom of the charge station 38 inches above the ground.
 - The mounting holes are spaced 16" apart to accommodate wall studs.
 - If you do not have solid structural framing on those centers, you must provide an adequate alternative mounting surface for the EVSE.
2. Attach the charge station to the wall studs using (4) ¼ x 2 ½ lag screws.
3. Use a multi-set or equivalent if mounting on a concrete wall.
4. Remove the applicable knock-out in the charge station, push the power leads through the hole, then connect the power conduit to the hole.

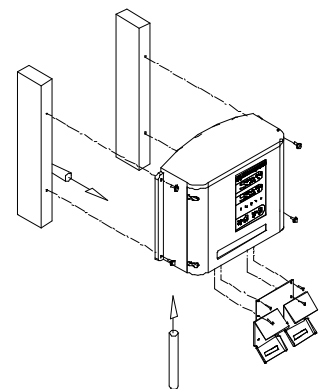

WIRING

WARNING: *Be sure the EVSE circuit breaker is OFF at the service or distribution panel before attempting wiring of the DS-200.*

Refer to the DS-200 User's Manual for instructions when connecting the Service Wiring.